



**RFS Technologies**  
an Amphenol Company

# RADIAFLEX<sup>®</sup> RADIATING CABLE

## SELECTION GUIDE

Edition 1 rev. A | 07.2023

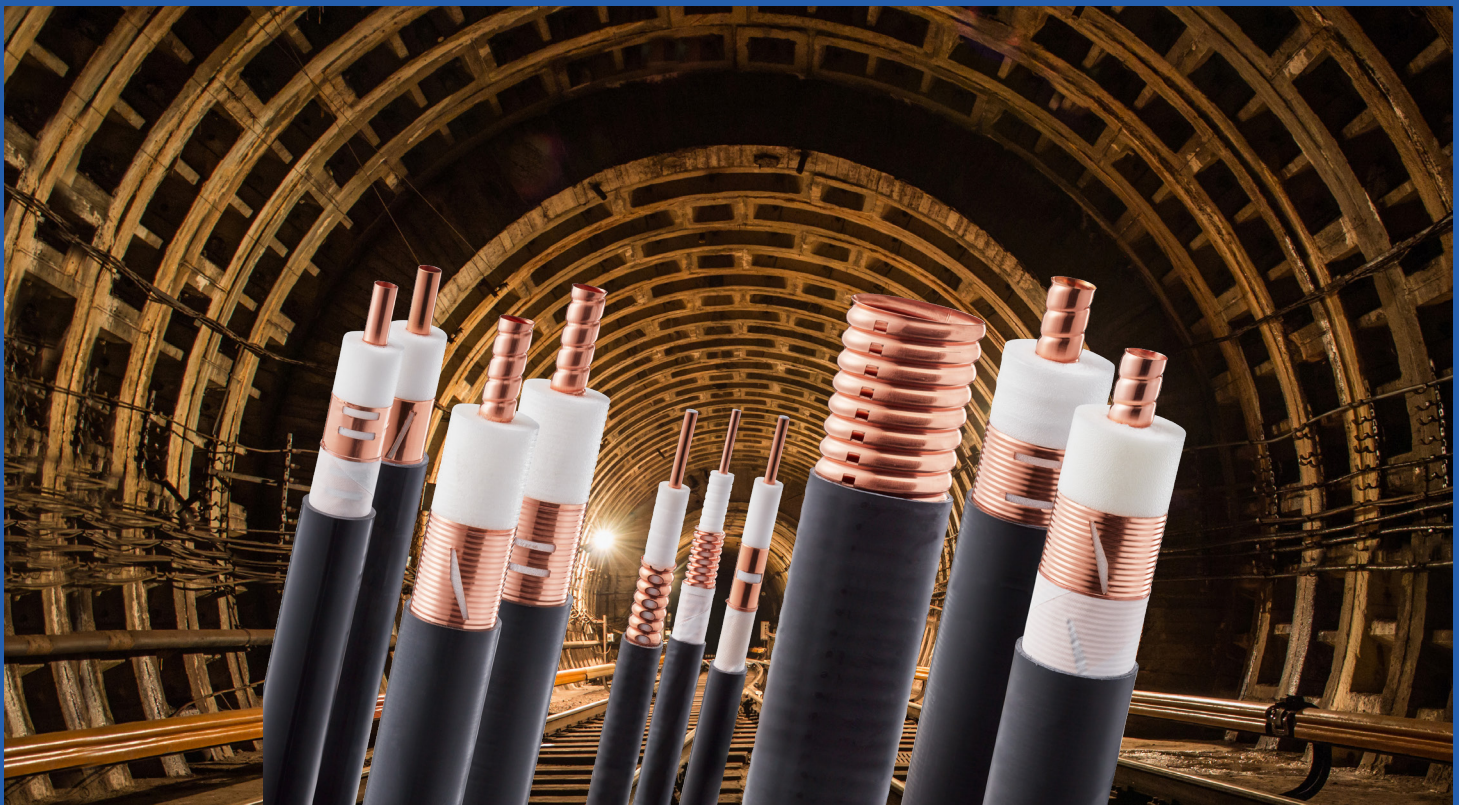

RFS TECHNOLOGIES, INC. INDOOR/IN-TUNNEL SOLUTIONS



# RFS TECHNOLOGIES, AN AMPHENOL COMPANY

## TABLE OF CONTENTS

### RADIAFLEX® CABLES

An introduction to the world's most advanced  
**portfolio of 5G-ready radiating cables** 2

### PORTFOLIO OVERVIEW

A synopsis of RFS RADIAFLEX cable  
**types, applications, and frequencies** 2

### MIMO SOLUTIONS

Take advantage of new spectrum and  
**accelerate to 5G in tunnels** 2

### RADIAFLEX SPECIFICATIONS

Find RADIAFLEX cables for  
**every application and environment** 2

### CONNECTORS FOR RADIAFLEX CABLES

Premium performance connectors  
**support quick, easy and reliable installations** 2

### STANDARD AND PREMIUM CONNECTORS

OMNI FIT connectors **for every application  
and budget** 4

### CELLFLEX® TECHNICAL INFORMATION

Cable, connector and accessory **data  
specifications** 6

### CLEARFILL® LINE PLENUM-RATED CABLES

Air-dielectric coaxial cables that operate in  
frequencies from 380 MHz **to 6 GHz** 13

### RF JUMPER CABLES

High-performance jumper cables  
**for any application, any size** 15

### ADAPTER SERIES

Easy field **connections** 18

### CELLFLEX® CABLE MODEL STRUCTURES

Understanding **RFS model numbers** 19

### JUMPER MODEL STRUCTURES

Understanding **RFS model numbers** 20



## THE WORLD'S MOST ADVANCED PORTFOLIO OF 5G-READY RADIATING CABLES

RADIAFLEX radiating cables take reliable, high-performance wireless coverage everywhere the cable is installed to eliminate the need for traditional antennas in confined indoor and underground spaces. These groundbreaking broadband cables changed the industry when we invented them in 1972, and they continue to set new benchmarks for speed, reliability and fire resistance today.

### FUTUREPROOF YOUR CONNECTIVITY INVESTMENTS

Every RADIAFLEX radiating cable is 5G-ready, and can simultaneously deliver all commercial and mission-critical services up to 6 GHz with high performance.

You can support multiband, multi-operator applications in the most challenging indoor and underground environments today, and smoothly evolve to take advantage of new spectrum and deliver new services over time — with no need to replace cables.

### FIND RADIAFLEX CABLES FOR EVERY APPLICATION AND ENVIRONMENT

With several different families of RADIAFLEX cables to choose from, you can find the right combination of bending radius, performance level and outer conductor type needed to support every application, in every environment. We offer RADIAFLEX cables that are optimized for:

- **5G applications** that require maximum throughput
- **Mission-critical applications** that require maximum reliability
- **High-frequency and digital applications** that require extremely low losses
- **Mining and industrial applications** that require maximum durability with no compromises to cable flexibility
- **In-vehicle applications** that require maximum cable flexibility
- **Long cable runs** with sustained high performance

We can also customize RADIAFLEX cables for your specific applications, environment and goals.

Used in more than  
**50%**  
of the world's  
metros and tunnels.



# THE WORLD'S MOST ADVANCED PORTFOLIO OF 5G-READY RADIATING CABLES

## INCREASE FIRE SAFETY TO PROTECT LIVES

RADIAFLEX cables are tested and proven to minimize flame spread and smoke emissions. You'll find RADIAFLEX cables that comply with:

- All major International Electromechanical Commission (IEC) standards for low smoke, flame and fire retardance:
  - IEC 60754-1/-2: Halogen-free and non-corrosive jacket tests
  - IEC 60332-1: Flame tests
  - IEC 60332-3-24: Cable bundle tests
  - IEC 61034: Low-smoke emission tests
- The highest Construction Products Regulation (CPR) standards for burning droplets (d0), low smoke emission (s1) and corrosivity (a1)
- The National Fire Protection Association (NFPA) 130 standard for Fixed Guideway Transit and Passenger Rail Systems

## SIMPLIFY END-TO-END DAS DEPLOYMENTS

To complement our RADIAFLEX radiating cables, we offer a complete family of installation tools, accessories, and coaxial cable solutions including:

- **RADIAFLEX cable connectors** that minimize passive intermodulation (PIM) to ensure interference doesn't affect quality of service or performance
- **Radiating waveguides** that simultaneously support multiple one-way and two-way communications systems so a single waveguide can be used for all applications
- **Robust clamps and smart fixing solutions** with fire-protection inserts for all installation scenarios
- **CELLFLEX® high-performance, flame-retardant coaxial cables, jumpers and OMNI FIT™ connectors** for every distributed antenna (DAS) deployment

## CHOOSE THE WORLD'S MOST TRUSTED RADIATING CABLES

RADIAFLEX radiating cables are delivering reliable, high-performance wireless connectivity in more than 50% of the world's metros and in iconic tunnels around the world, including:

- Grand Paris Express rapid transit lines
- Follobanen high-speed railway
- Metro Rio De Janeiro
- New York Metro
- Singapore Metro
- Hong Kong metro
- London Crossrail railway
- Eurotunnel
- Fréjus road tunnel
- CERN Super Proton Synchrotron (SPS)

## RELY ON OUR WORLD-RENOUNDED EXPERTISE

As the world's leading experts in radiating cable technologies, we've provided technical insight, guidance and fully customized solutions for some of the most unique and challenging wireless connectivity deployments globally. We can help you:

- Deliver reliable, uninterrupted wireless connectivity in hostile, ultra-confined underground environments with poor ventilation
- Ensure optimal radio signal propagation in areas where tunnel curves and signal blockages due to passing trains significantly increase complexity
- Maintain signal strength and quality inside fast-moving trains packed with passengers while compensating for losses caused by train materials and human bodies

Learn about our latest successes: <https://bit.ly/3SAoy31>



# PORTFOLIO OVERVIEW

## RADIAFLEX RADIATING CABLES

	5G Commercial Radio									
	Mission Critical		4G Commercial Radio							
	75-450 MHz	600-960 MHz	617-960 MHz	1700-1900 MHz	2200 MHz	2700 MHz	3800 MHz	4200 MHz	4900 MHz	6000 MHz
<b>5G RADIAFLEX Radiating Cable Solution</b>										
RLKX114-50*	+	++	++	++	++	+++	+++			
RLKX114-50B	+	++	++	++	++	+++	+++	+++		
RAYX114-50*	+	++	++	++	++	+++	+++			
RLKAX12-50	+	+	+	+	++	++	++	++	++	++
RE60										+++
<b>4G RADIAFLEX Radiating Cables</b>										
RLKU158-50*	+	++	++	+++	+++	+++				
RAYA158-50*	+	++	++	+++	+++	+++				
RLKU114-50*	+	++	++	+++	+++	+++				
RAYA114-50*	++	++	++	+++	+++	+++				
RLKU78-50	+	++	++	+++	+++	+++				
RLKU12-50	+	++	++	+++	+++	+++				
<b>Mission Critical Radio Application</b>										
RLK158-50	+++	++	++							
RLK114-50	+++	++	++							
RLK78-50	+++	++	++							
RLK12-50	+++	++	++							
RLKW114-50	++	+++	+++	++						
RLKW78-50	++	+++	+++	++						
RLKW12-50	++	+++	+++	++						
<b>GSM-R Applications</b>										
RAY158-50	++	+++	+++							
RAY114-50	++	+++	+++							
RAY78-50	++	+++	+++							
<b>Diverse Applications</b>										
RCF12-50	+	+	+	+	+	+	+	+	+	+
RSF12-50	+	+	+	+	+	+	+	+	+	+
RCF78-50	+	+	+	+	+	+	+			
RLFU158	++	++	++	++	++					
RLFU114	++	++	++	++	++					
RLFU78	++	++	++	++	++					

\* MIMO cables

## ACCELERATE TO 5G IN TUNNELS WITH THE WORLD'S FASTEST MIMO SOLUTIONS

In 2018, we set a world record for in-tunnel download speeds with a dual-cable MIMO solution that reached 560 Mb/s. We did it by combining two perfect-match RADIAFLEX cables: one with horizontal polarization and one with vertical polarization.

Today, we offer the world's first pair of ultra-broadband radiating cables for cross-polarized MIMO applications to help you achieve the fastest possible MIMO speeds. When these patented RADIAFLEX cables are combined, the cross-polarization effects optimize channel decorrelation conditions to maximize throughput efficiency in 2x2, 4x4 and higher MIMO applications.

### TAKE ADVANTAGE OF NEW SPECTRUM

Our unique mode suppression technology means RADIAFLEX are the only radiating cables on the market that can operate in all 3GPP standardized frequency bands up to 4.2 GHz with no stopbands. As a result, they're ideal to take advantage of 3.5 GHz spectrum and deliver the next generations of commercial and mission-critical services. They also simplify spectrum rebanding and refarming projects so you can flexibly adapt your operations to support new applications and services as needed.

### SEE THE TEST RESULTS FOR YOURSELF

Our direct comparison of single- and dual-cable MIMO test cases confirms a dual-cable, dual-polarized MIMO configuration outperforms a single-cable configuration and a dual-cable configuration where both cables have the same polarization.

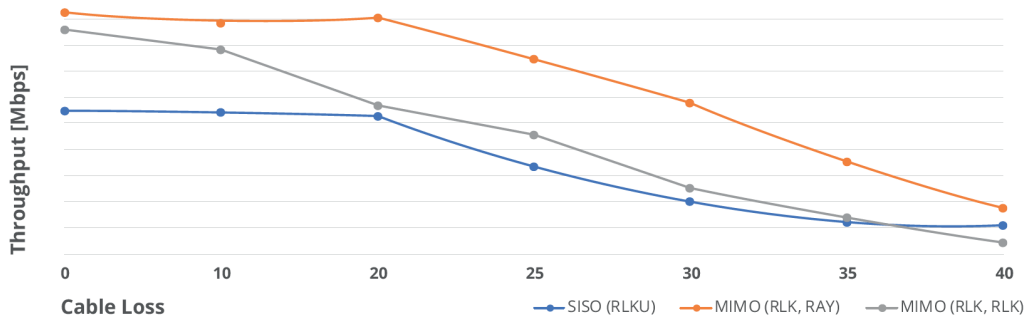

### BUILD YOUR DUAL-CABLE RADIAFLEX SOLUTION

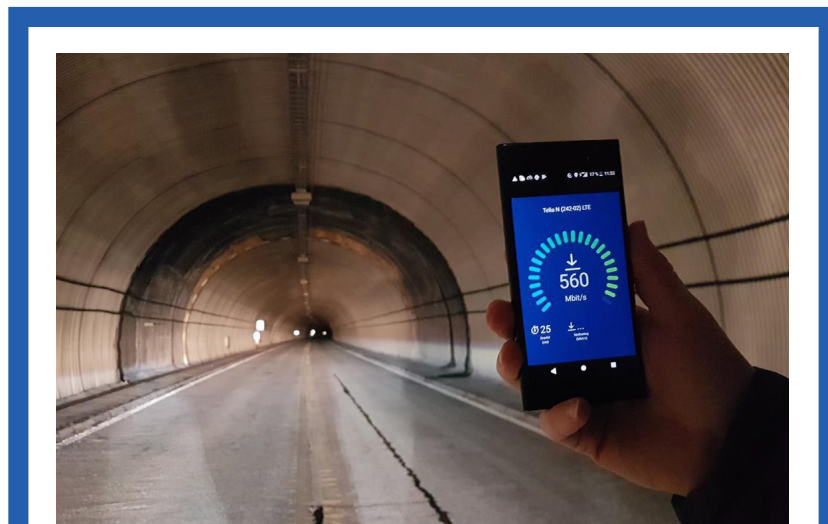

To optimize MIMO conditions in your environment, combine one cable from our vertically polarized RAY cable family and one from our horizontally polarized RLK cable family:

- 4G: RAYA158 and RLKU158
- 5G: RAYX114 and RLKX114





## 5G RADIAFLEX RADIATING CABLES

MODEL NAME	RLKX114	RAYX114	<b>COMING SOON</b>
Product Profile			
Maximum Operating frequency	4200MHz		
Dominant Polarization in dedicated bands of operation	Horizontal	Vertical	
Application	Commercial and mission critical radio applications in all kind of metro, rail and street tunnels		
Characteristics and Features	<p><b>An Unbeatable Feature Set</b> Optimized for Performance</p> <p><b>Unique Radiating Cable Design</b> The only cable available with no stop bands across the full spectrum</p> <p><b>Ultra-broadband RF Bandwidth</b> Simultaneously supports all 2G, 3G, 4G and 5G commercial wireless bands and all mission-critical bands</p> <p><b>A solution for any MIMO Application</b> Supports all single, dual, and multiple MIMO design approaches</p> <p><b>Ready for the Future</b> Supports additional wireless services up to 3800 MHz, or allows for spectrum re-banding/re-farming</p>		



MODEL NAME	RLKAX12	RE60
Product Profile		
Maximum Operating frequency	7200MHz	5000-6000MHz
Dominant Polarization in dedicated bands of operation	Horizontal	Vertical
Application	all tunnel and indoor environments	
Characteristics and Features	<ul style="list-style-type: none"> <li>• Ultra-broadband applications in wireless local-area networks (WLANs) and 5G frequency bands</li> <li>• Support of all 802.11 standards including latest 802.11ax</li> </ul>	<ul style="list-style-type: none"> <li>• Optimized RF conditions allow for lowest overall TCO in the 6000MHz spectrum                             <ul style="list-style-type: none"> <li>• Best system performance ensures longest amplifier spacings and related ecological aspects such as CO2 savings</li> </ul> </li> <li>• Lowest system loss performance: the RE60 has a comparable system loss at 6 GHz than radiating cables operating in the 2.4 GHz ISM band</li> </ul>



## 4G RADIAFLEX RADIATING CABLES

MODEL NAME	RLKU158   RLKU114   RLKU78   RLKU12	RAYA158   RAYA114
Product Profile		
Maximum Operating frequency	2700MHz	
Dominant Polarization in dedicated bands of operation	Horizontal	Vertical
Application	All types of metro, rail and street tunnels	
Characteristics and Features	<p><b>An Unbeatable Feature Set</b> Optimized for Performance</p> <p><b>Unique Radiating Cable Design</b> The only cable available with no stop bands across the full spectrum</p> <p><b>Ultra-broadband RF Bandwidth</b> Simultaneously supports all 2G, 3G, 4G and 5G commercial wireless bands and all mission-critical bands</p> <p><b>A solution for any MIMO Application</b> Supports all single, dual, and multiple MIMO design approaches</p> <p><b>Ready for the Future</b> Ensures the most futureproof confined coverage installation</p>	

## MISSION CRITICAL RADIO APPLICATIONS

MODEL NAME	RLK158   RLK114   RLK78   RLK12	RLKW158   RLKW114   RLKW78   RLKW12
Product Profile		
Maximum Operating frequency	980MHz	1950MHz
Dominant Polarization in dedicated bands of operation	Horizontal	
Application	All types of metro, rail and street tunnels; in-building applications	
Characteristics and Features	<ul style="list-style-type: none"> <li>• Optimized for Performance</li> <li>• The only cable available with no stop bands across the full spectrum</li> <li>• Simultaneously supports all 2G, 3G, 4G and 5G</li> </ul>	

## GSM-R APPLICATIONS

MODEL NAME	RAY158   RAY114   RAY78
Product Profile	
Maximum Operating frequency	1000MHz
Dominant Polarization in dedicated bands of operation	Vertical
Application	GSM-R type applications
Characteristics and Features	<ul style="list-style-type: none"> <li>• Dominant vertical polarization makes this cable ideal for operation on vertically polarized train antennas</li> <li>• Combined VHF, TETRA and GSM-R systems</li> </ul>



## DIVERSE APPLICATIONS

MODEL NAME	RCF12	RCF78	RSF12
Product Profile			
Maximum Operating frequency	6000MHZ	3800MHz	6000MHz
Dominant Polarization in dedicated bands of operation	Homogenous		
Application	Installation on various confined areas with challenging installation constraints		
Characteristics and Features	<ul style="list-style-type: none"> <li>• MSHA approved cable for mining industry</li> <li>• Improved mechanical properties to ensure installation under challenging environmental conditions</li> <li>• Ideally suited for applications that require low bending radii</li> </ul>		<ul style="list-style-type: none"> <li>• Ultra-flexible design of the cable make it ideally suited for in-train installation and in-vehicle installation as well as in-building</li> <li>• Ideally suited for applications that require low bending radii</li> </ul>

MODEL NAME	RLFU158   RLFU114   RLFU78
Product Profile	
Maximum Operating frequency	2400MHz
Dominant Polarization in dedicated bands of operation	Homogenous
Application	Heavy-duty wideband radiating cable for multi-use applications in tunnels of all kinds
Characteristics and Features	<ul style="list-style-type: none"> <li>• Withstands hostile environmental conditions such as dirty or dusty tunnels</li> </ul>

## CONNECTORS FOR RADIAFLEX RADIATING CABLES

Premium Performance Radiating Cable Connectors Support Quick, Easy and Reliable Installation



### PIM-RATED FOR THE HIGHEST QUALITY CONNECTOR-CABLE INTERFACE

RFS' PIM-rated radiating cable connectors are designed specifically to provide the highest quality connector-cable interface while simplifying and speeding up the attachment of connectors to RFS radiating cables. Connectors are available in 7-16 DIN interfaces (additional models for type N interfaces coming soon). The robust two-piece mechanical design enables a stable connection with the cable for best-in-class PIM performance. The connectors consist of both a back nut and body for secure positioning, and then are pre-assembled before delivery and easily attach to the prepared cable in one piece. This assures error-free attachment and avoids unnecessary connector adjustments, while allowing for reuse and repositioning in the future as needed.

RFS connectors are completely waterproof to assure safe, long-term operation in the harshest of environments. All connectors are fully tested for mechanical and electrical and compliance specifications and provide low VSWR for excellent electrical performance.

- **Fast and easy installation** — eliminates unnecessary connector adjustments and provides outstanding performance
- **Robust mechanical design** — Provides best-in-class PIM performance
- **Low VSWR** — Ensures excellent electrical performance
- **Totally waterproof** — provides safe, long-term operation in the harshest of environments

## CONNECTOR **INSTRUCTIONS**

Access Installation Sheets

**Fast and easy access to installation instructions:**

- Printed instructions available in every connector box
- On the go – access the installation docs from a link on the datasheets



## CONNECTORS FOR RADIAFLEX RADIATING CABLES

CABLE TYPE (* = JACKET OPTION)	STANDARD CONNECTOR	INSTALLATION PREPARATION TOOL	PREMIUM CONNECTOR	INSTALLATION PREPARATION TOOL
<i>1/2" Cable Size (Diameter)</i>				
RFS12-50*	43M-SCF12-C03	TRIM-SET-S12-C02	43M-SCF12-E01* <sup>2</sup>	TRIM-SET-S12-D01
	43F-SCF12-C03	TRIM-SET-S12-C02	43F-SCF12-E01* <sup>2</sup>	TRIM-SET-S12-D01
	NF-SCF12-C03	TRIM-SET-S12-C02	NF-SCF12-E01* <sup>2</sup>	TRIM-SET-S12-D01
	NM-SCF12-C03	TRIM-SET-S12-C02	NM-SCF12-E01* <sup>2</sup>	TRIM-SET-S12-D01
	716F-SCF12-C03	TRIM-SET-S12-C02	716F-SCF12-E01* <sup>2</sup>	TRIM-SET-S12-D01
	716M-SCF12-C03	TRIM-SET-S12-C02	716M-SCF12-E01* <sup>2</sup>	TRIM-SET-S12-D01
RCF12-50*	43M-LCF12-C03* <sup>2</sup>	TRIM-SET-L12-C02	43M-SCF12-E01* <sup>2</sup>	TRIM-SET-L12-D01
	43F-LCF12-C03* <sup>2</sup>	TRIM-SET-L12-C02	43F-SCF12-E01* <sup>2</sup>	TRIM-SET-L12-D01
	NM-LCF12-C03* <sup>2</sup>	TRIM-SET-L12-C02	NF-SCF12-E01* <sup>2</sup>	TRIM-SET-L12-D01
	716M-LCF12-C03* <sup>2</sup>	TRIM-SET-L12-C02	716F-SCF12-E01* <sup>2</sup>	TRIM-SET-L12-D01
RLK12-50* RLKW12-50* RLKU12-50*	NF-RA12-012	not required	43F-RA12-P02* <sup>3</sup>	TRIM-SET-R12-P02
	NM-RA12-011	not required	NF-RA12-P02* <sup>3</sup>	TRIM-SET-R12-P02
	N/A	N/A	NM-RA12-P02* <sup>3</sup>	TRIM-SET-R12-P02
<i>7/8" Cable Size (Diameter)</i>				
RCF78-50*	43M-LCF78-C03* <sup>3</sup>	TRIM-SET-L78-C02	43M-LCF78-E01* <sup>3</sup>	TRIM-SET-L78-E01
	43F-LCF78-C03* <sup>3</sup>	TRIM-SET-L78-C02	43F-LCF78-E01* <sup>3</sup>	TRIM-SET-L78-E01
	NF-LCF78-C03* <sup>3</sup>	TRIM-SET-L78-C02	NF-LCF78-E01* <sup>3</sup>	TRIM-SET-L78-E01
	NM-LCF78-C03* <sup>3</sup>	TRIM-SET-L78-C02	NM-LCF78-E01* <sup>3</sup>	TRIM-SET-L78-E01
	716F-LCF78-C03* <sup>3</sup>	TRIM-SET-L78-C02	716F-LCF78-E01* <sup>3</sup>	TRIM-SET-L78-E01
	716M-LCF78-C03* <sup>3</sup>	TRIM-SET-L78-C02	716M-LCF78-E01* <sup>3</sup>	TRIM-SET-L78-E01
RLK78-50* RLKW78-50* RLKU78-50*	NF-RA78-016	not required	43F-RA78-P02* <sup>3</sup>	TRIM-SET-R78-P02
	NM-RA78-015	not required	716F-RA78-P02* <sup>3</sup>	TRIM-SET-R78-P02
	716F-RA78-016	not required	716M-RA78-P03* <sup>3</sup>	TRIM-SET-R78-P02
	716M-RA78-015	not required		
<i>1-1/4" Cable Size (Diameter)</i>				
RLF114-50* RLFU114-50* RLK114-50* RLKW114-50* RLKX114-50*	NF-RA114-016	not required	43F-RA114-P02	TRIM-SET-R114-P02
	716F-RA114-016	not required	716F-RA114-P02	TRIM-SET-R114-P02
<i>1-5/8" Cable Size (Diameter)</i>				
RLF158-50* RLFU158-50* RLK158-50* RLKW158-50* RLKU158-50* RAY158-50* RAYA158-50*	NF-RA158-016	not required	43F-RA158-P02	TRIM-SET-R158-P02
	716F-RA18-016	not required	716F-RA158-P02	TRIM-SET-R158-P02

### Heat Shrink Sleeves

USE FOR:	MODEL NUMBER
RSF 12-50* cable connectors	HEAT-328-012
RCF 12-50* cable connectors	HEAT-328-018
RCF 78-50* cable connectors	HEAT-3812-014
RCF 114-50* cable connectors	HEAT-5016-024
RCF 158-50* cable connectors	HEAT-6319-026

### ORDERING INFORMATION

\* Cable jacket option, e.g. JFN, JFL, CPR

\*2 An additional heat shrink sleeve is required and must be ordered

\*3 In order to achieve the PIM specification, the use of the noted trimming tool is required.

## CABLES AND CONNECTORS FOR EVERY TUNNEL AND INDOOR APPLICATION

In addition to RADIAFLEX®, RFS offers CELLFLEX® coaxial cables. They are designed to meet in-building and in-tunnel communications requirements today and tomorrow. Our high-quality connectors maintain signal integrity end-to-end.

### CELLFLEX® LOW-LOSS CABLES

CELLFLEX cables make up the largest corrugated transmission-line portfolio in the wireless infrastructure industry. The foam dielectric cables combine remarkable flexibility with high strength and superior electrical performance to ensure uninterrupted communications. This premium transmission line family is backed by a complete line of accessories, including the renowned OMNI FIT™ connector range.

Twenty unique CELLFLEX types, ranging in size from 1/4" to 1-5/8", provide users with a perfect match for even the most complicated and demanding applications. Every cable comes with a guarantee of reliability, performance and cost-effectiveness.

### OMNI FIT™ CONNECTOR FAMILIES

RFS connectors are designed for high performance, easy installation and full compatibility throughout the CELLFLEX family. The entire range of innovative OMNI FIT™ Premium and OMNI FIT™ Standard connectors work with all CELLFLEX® cables. A perfect complement to the CELLFLEX® transmission line range, OMNI FIT™ connectors provide users with familiar connection options, premium electrical characteristics and reliable, long-life use.

RFS' OMNI FIT™ Standard connectors are designed to meet and exceed industry standard Voltage Standing Wave Ratio (VSWR) and PIM performance. The connectors offer a cost-effective, high-quality connector-to-cable interface for easy, fast and safe connector attachment.

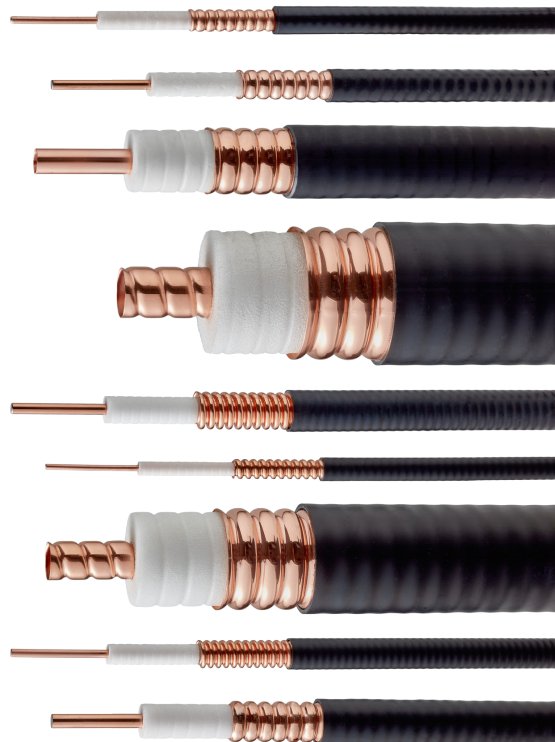

### COMPLETE SHIELDING

The solid outer conductor on CELLFLEX coaxial cables creates a continuous RF/EMI shield that minimizes system interference.

### LOW VSWR

Special low voltage standing wave ratio (VSWR) CELLFLEX variants help maintain system integrity.

### OUTSTANDING INTERMODULATION PERFORMANCE

The solid inner and outer conductors virtually eliminate intermodulation.

### HIGH POWER RATING

Low attenuation, excellent heat transfer properties and temperature stabilized dielectric material ensure safe, long-term operation at high transmit power levels.

### WIDE RANGE OF APPLICATIONS

CELLFLEX cables support frequency bands up to 6000 MHz to enable a wide range of in-building applications.



## INSTALL RADIAFLEX WITH CONFIDENCE

### RADIAFLEX INSTALLATION ASPECTS AND ACCESSORIES

#### Positioning the cables

RADIAFLEX® cables are available with bulges or guides. In order to achieve the best performance, the guides and the bulges should be installed in a defined position.

In order to achieve the best performance of radiating waveguides the slots should be installed in direction of coverage. The slots are marked by the printing on the jacket.

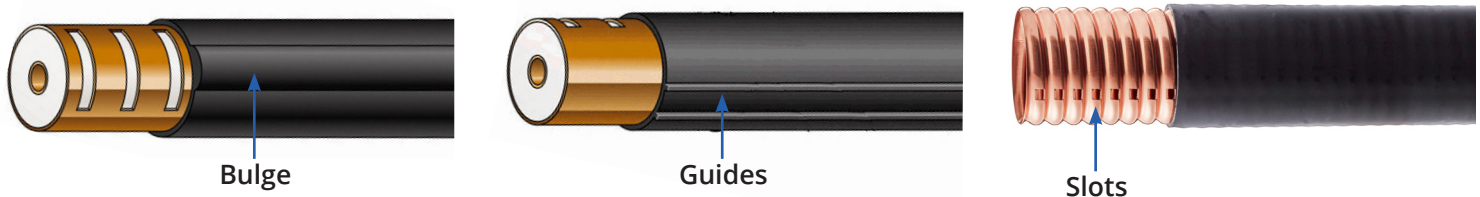

#### SMART FIXING SOLUTION (SFS) CLAMP SERIES

The Smart Fixing Solution (SFS) clamp family ensures a safe and reliable RADIAFLEX cable installation in harsh environmental tunnel conditions. The SFS clamps also allow for an optimized installation process minimizing customer's total cost of ownership (TCO) – an aspect that is essentially important as installation time in tunnel environment is a key factor in deployments affecting overall solution cost.

#### SAFE & RELIABLE INSTALLATIONS WHERE CRITICAL COMMUNICATION IS ESSENTIAL

The SFS clamps are based on a one-piece, self-closing plastic pipe clamp for the fixing of radiating cables in road, railway and metro tunnels. The SFS clamps also allow for more flexibility regarding compatibility regarding installation hardware such as e.g. screws, dowels and, consequently, allow for easier adaptation to customer specific installation need.

The SFS clamps in combination with RFS worldwide leading RADIAFLEX radiating cable portfolio have also been optimized to avoid any passive intermodulation (PIM) effects which is particularly important in highly reflective in tunnel environments to avoid network interferences and ensure highest possible network throughput.

The clamps also feature a fire secured mounting functionality by allowing additional metal cable ties to be installed together with the SFS clamps.

SFS Clamps offer:

- Simple and quick assembly
- Closing system without additional screws
- Secure closure, no opening
- Fixed wall distance 80 mm
- Integrated fire protection device
- Anchor and screw fastening available with standard products; Bolt setting technology is also available



# INSTALL RADIAFLEX WITH CONFIDENCE

## SFS Clamp Types

MODEL NUMBER	USE
SFS-12-01	for 1/2" cables (except RSF12)
SFS-78-01	for 7/8" cables
SFS-114-01	for 1-1/4" cables
SFS-158-01	for 1-5/8" cables

## Fixation Options

MODEL NUMBER	DESCRIPTION
SFS-PLUG-6-01	Plastic Dowel
SFS-SC650-02	Screw for Plastic Dowel
SFS-FIX-644-02	Metal Plug with Head
SFS-FIX-649-02	Metal Plug with Nut

MODEL NUMBER	DESCRIPTION
TOOL-SFS-FIX-01	Setting tool for SFS Metal Plug with head / nut
TOOL-SFS-FIX-D	Drilling tool for SFS Metal Plug with head / nut

## BEST PRACTICES DURING THE INSTALLATION PROCESS

Care should be taken to ensure that the hole is always drilled at right angles to the surface of the wall so that the clamps do not become twisted during the subsequent assembly. The hole should be cleaned out with an air pump after drilling. Three different fixing options are available. Make sure the clamps are lined up; otherwise, the cable will not run in a perfectly straight line. After installing the cable, the clips are closed by simply pressing the closure into position.

This insert (metallic tie) for SFS clamp types was developed for situations which require the cable to remain functional for as long as possible in the event of a fire. The cable should not become detached from the wall or ceiling in order to prevent an escape route from being blocked.

In case of fire, the resistant part of the fixing will hold the cable in position and enables the cable to keep in operation as long as the cable itself allows. The recommended installation spacing for these clamps is approximately every 8-10 m.

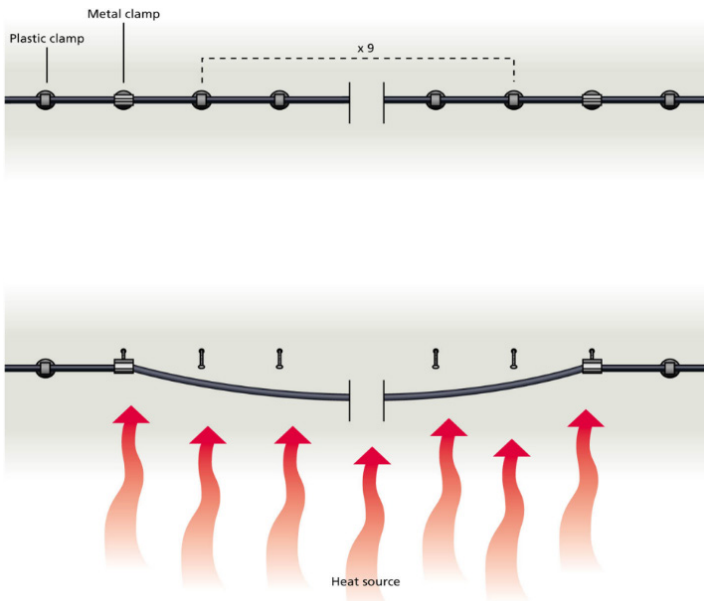



## INSTALL RADIAFLEX WITH CONFIDENCE

### PREVENT PIM INTERFERENCE TO MAINTAIN OVERALL SYSTEM PERFORMANCE

Radiating cables are distributed antennas and, consequently, metal obstacles in close proximity to the cable – notably to the radiating slots – may impact radiation behavior and might cause passive intermodulation (PIM) effects. This is especially true in scenarios where a metal dowel and the metal tie wrapped around the cable might make contact. PIM effects might significantly degrade overall system performance and KPI's for wireless communication systems. In order to avoid metallic contact between the fire secured tie and the metal dowel, a plastic insert has been provided to ensure the highest possible robustness against PIM interferences.

### Fire Protection Inserts

MODEL NUMBER	USE	SIZE
SFS-12-F	for SFS-12-01 clamp (1/2")	L = 247 mm (9.72 in)
SFS-78-F	for SFS-78-01 clamp (7/8")	L = 300 mm (11.81 in)
SFS-114-F	for SFS-114-01 clamp (1-1/4")	L = 330 mm (12.99 in)
SFS-158-F	for SFS-158-01 clamp (1-5/8")	L = 335 mm (13.18 in)

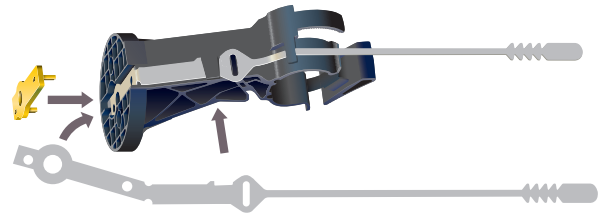

### RADIAFLEX INSTALLATION ASPECTS AND ACCESSORIES

#### Clic Clamp Installation

RLK, RAY and RLV type RADIAFLEX cables require a round base with a height  $H = 80$  mm. These clamps are fixed with a plastic plug  $\varnothing 6$  mm and a stainless steel screw.

Care should be taken to ensure that the hole is always drilled at right angles to the surface of the wall so that the clamps do not become twisted during the subsequent assembly. The hole should be cleaned out with an air pump after drilling. The clamp is fixed by means of a round head wood-screw tightened with a TORX bit screw driver (T 25) or with a cordless electric screwdriver and corresponding TORX bit.

Make sure the clamps are lined up; otherwise the cable will not run in a perfectly straight line. The minimum bending radii for installing cables should also be taken into account when fixing the clamps. When attaching the cable, the action of pressing the cable into the clamp with the hand causes the clamp to close automatically.

Please refer to the datasheet of the individual cable to review the recommended clamp spacing.

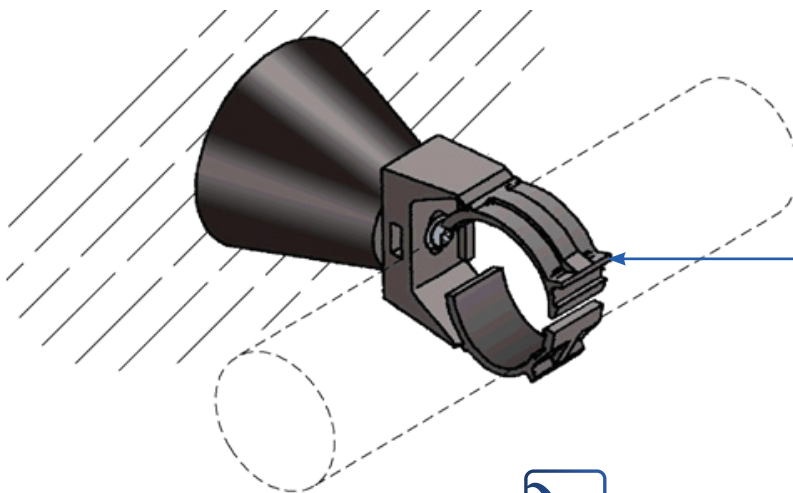

#### POSITION

Pay attention to the bulge or guides on the cable jacket

#### CLIC-CLAMP

Mount the cables by simply pushing the cable in by hand. The clamp will grip and lock by applying light pressure

## INSTALL RADIAFLEX WITH CONFIDENCE

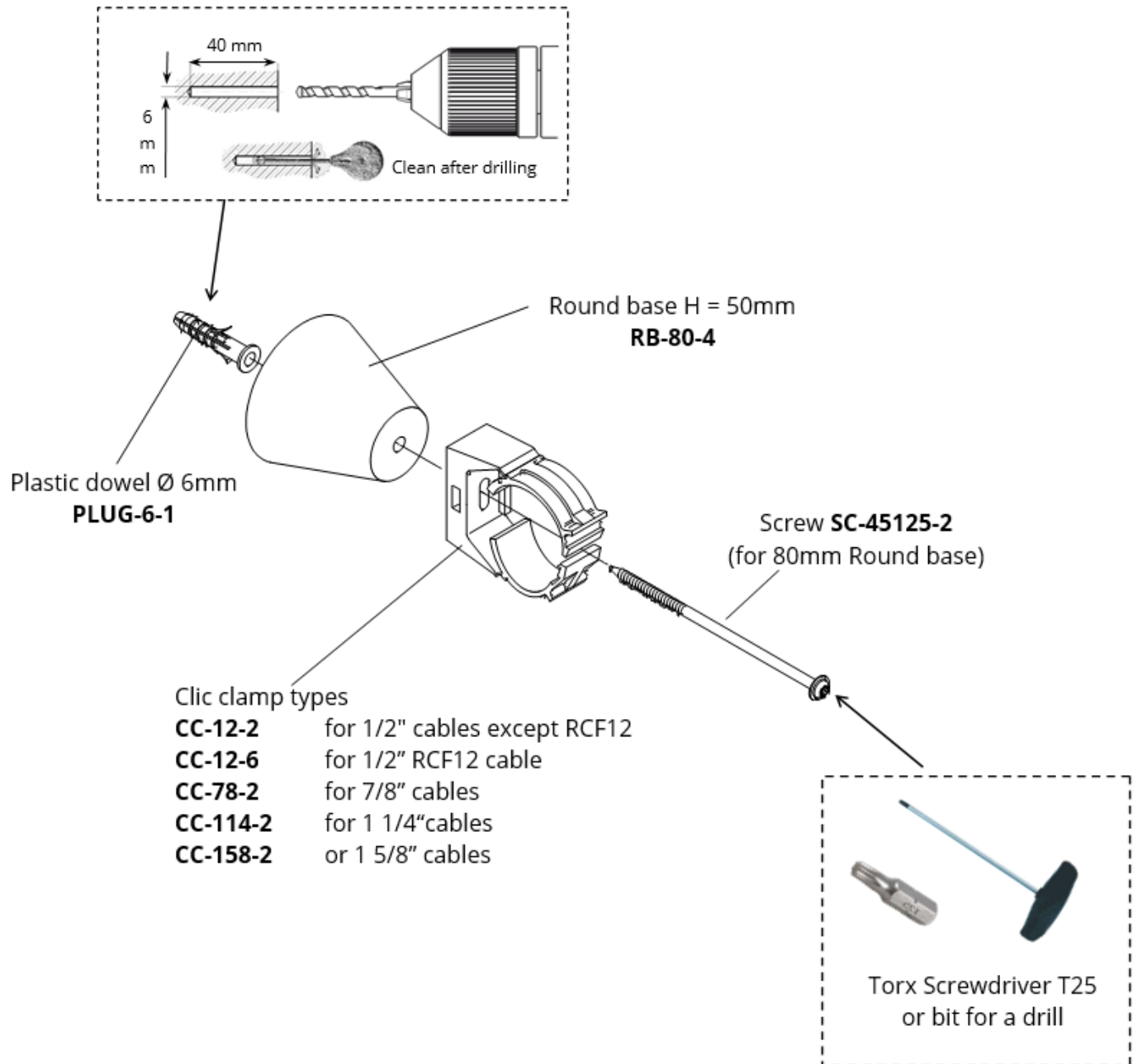

# INSTALL RADIAFLEX WITH CONFIDENCE

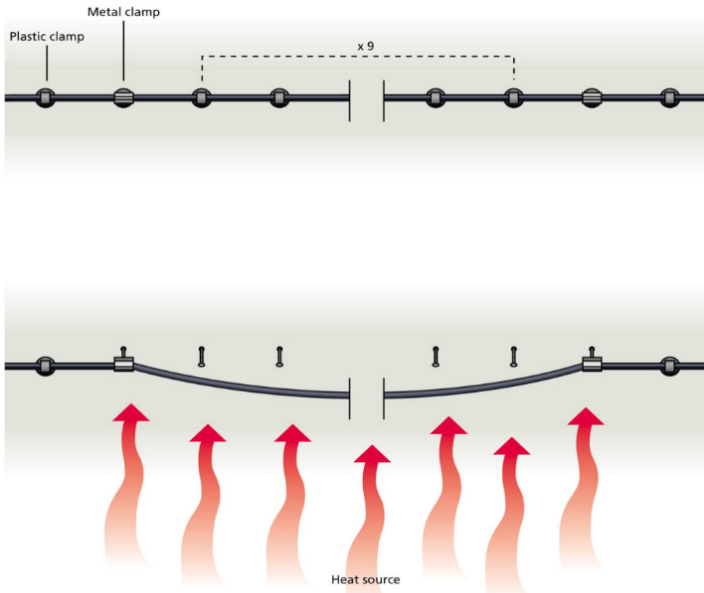

### SAFETY IS KEY

In case of fire, the resistant part of the fixing will hold the cable in position and enables the cable to keep in operation as long as the cable itself allows. It also prevents the cable from detaching from the wall which could block escape routes.

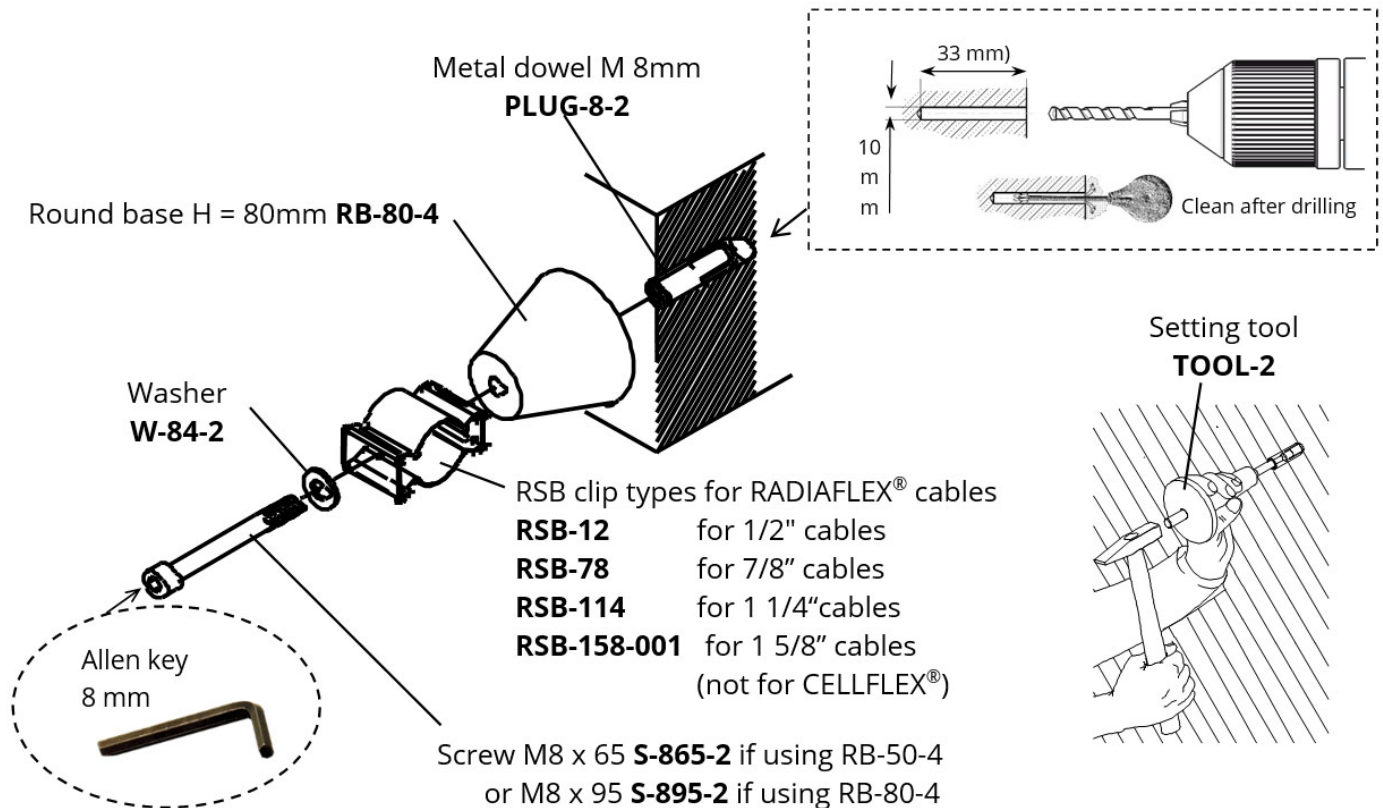

# RADIAFLEX 101

## RADIATING CABLE BASICS

RFS RADIAFLEX cables support all services up to 6 GHz with high performance, making them ideal for multiband, multi-operator applications in the most challenging indoor and underground environments.

### HOW THEY WORK

- Coaxial cable designed and constructed to radiate and receive RF energy over its entire length.
- Designed to replace traditional antennas
- Ensure line of sight everywhere between radio system and antenna
- Combined with other indoor solutions products to enhance RF coverage

### Frequency Range

The design of the apertures in the outer conductor influences the frequency for which the cable is optimized. RADIAFLEX® cables are usually classified into categories: for operation up to 960 MHz, 1900 MHz and 2700 MHz (6000 MHz). Cables optimized for special frequency ranges are available on request

### Longitudinal Loss

This is a measure of signal loss in the cable over its entire length

### Coupling Loss

This is a measure of the signal loss between the cable and a test receiver at a distance of 2m (6.5ft)

### System Loss

This is the sum of longitudinal loss and coupling loss

### Reception probability

50% - where 50 percent of all measured samples are better than stated performance figures

95% - where 95 percent of all measured samples are better than stated performance figures

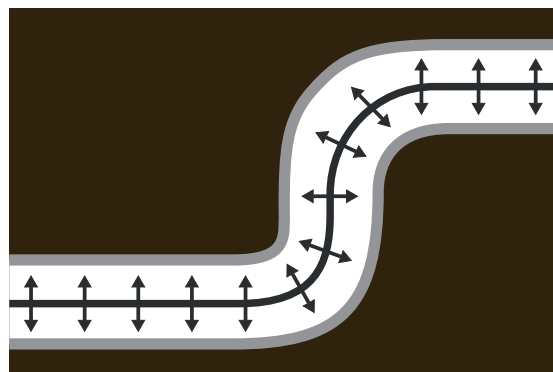

### NORMAL RF CABLE



### RADIATING CABLE



Transmitting (downlink)



Receiving (uplink)

### HOW IS THIS DONE

By cutting holes or slots in the outer conductor of coaxial cables, enabling RF power to enter or leave the cable.

# RADIAFLEX 101

## RADIATING CABLE BASICS

### LONGITUDINAL LOSS $a_l$ SIGNAL LOSS IN CABLE

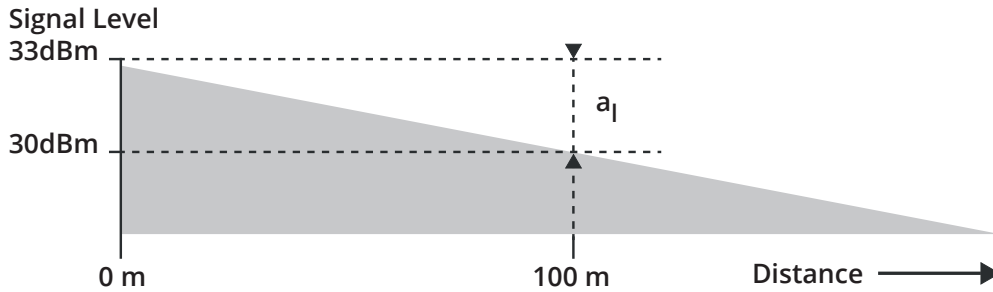
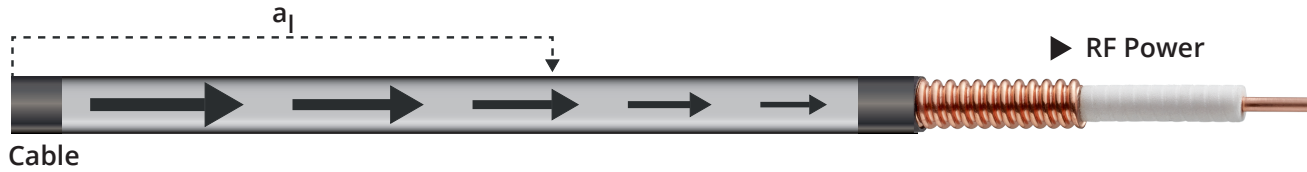

Example:  $a_l = 3 \text{ dB} / 100 \text{ m}$   
Note:  $a_l$  increases with frequency!

### COUPLING LOSS $a_c$ SIGNAL LOSS BETWEEN CABLE AND MOBILE DEVICE

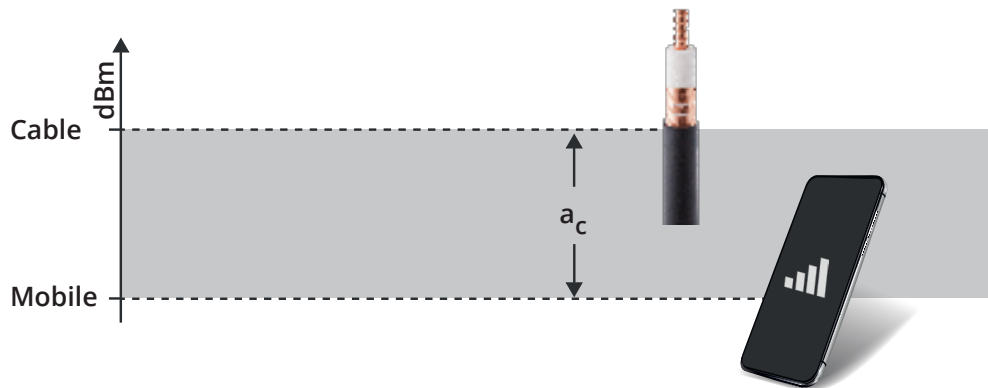

# RADIAFLEX 101

## RADIATING CABLE BASICS

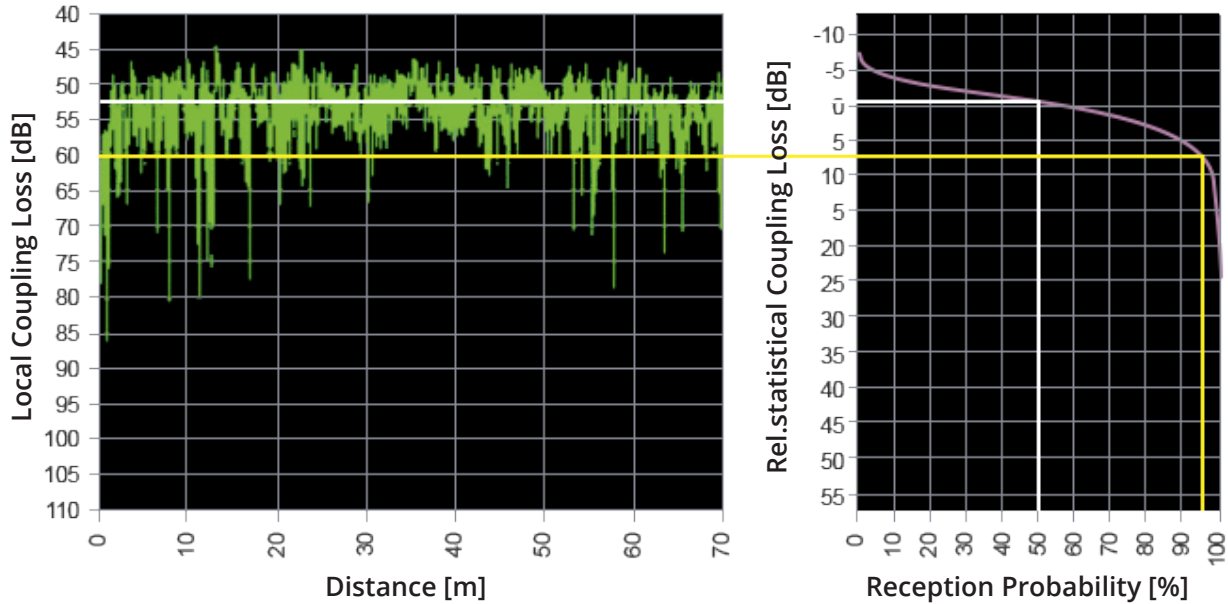

### ACCORDING TO IEC 61 196-4

Standard measurement along a cable run of approx. 100 m length

### MEASUREMENT CONDITIONS

- Free space
- No environmental influences
- No tunnel effects

### COUPLING LOSS MEASURED BY

- Height above ground: 2 m
- Distance between cable and antenna: 2 m
- Type of antenna:  $\lambda/2$  dipole
- Spatial orientation of dipole antenna: radial, orthogonal or parallel

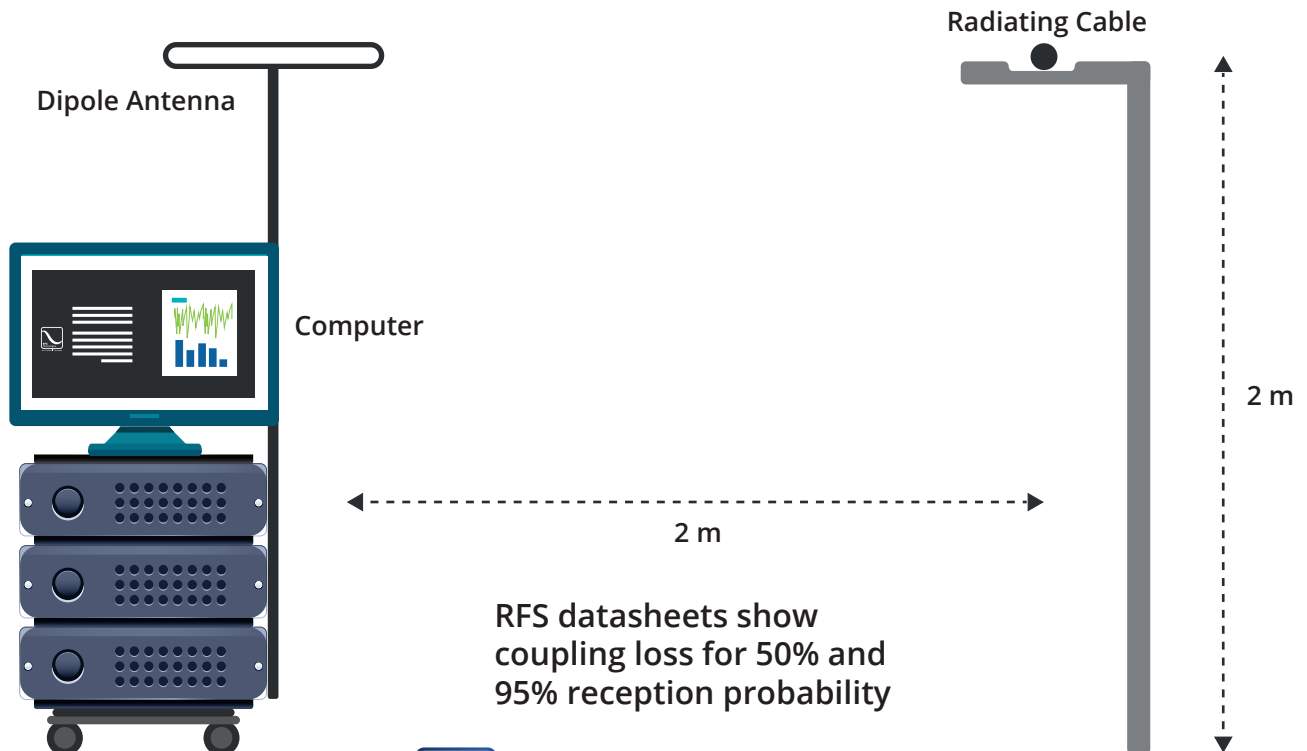

## NOTES

---

---

---

---

---

---

---

---

---

---

---

---

---

---

---

---

---

---

---

---

---

---

---





an Amphenol Company